

leak

The monitor with the captured images is placed in such a way as to deny simultaneous viewing of the live drips. Each experience is separated in the space to accentuate the disconnection between actual events and the images of it. More and more the world is perceived through processed means. What is real is increasingly controversial. Conflating and misusing these disparate modes of perception *leak* generates additional approaches in experiencing the environment.

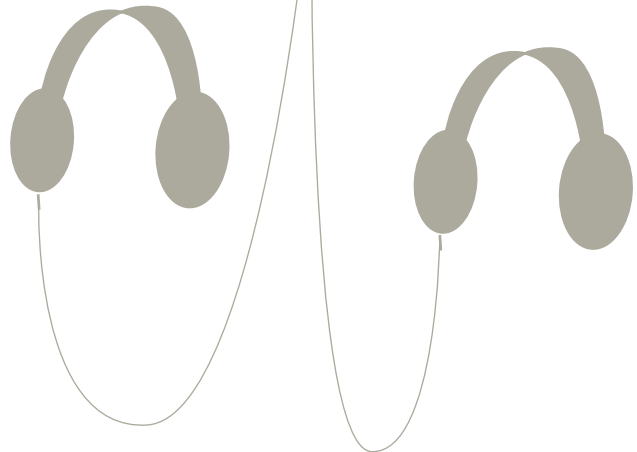

sheet of clear vinyl with water (12.5 gallons)
is attached to a corner of the ceiling.

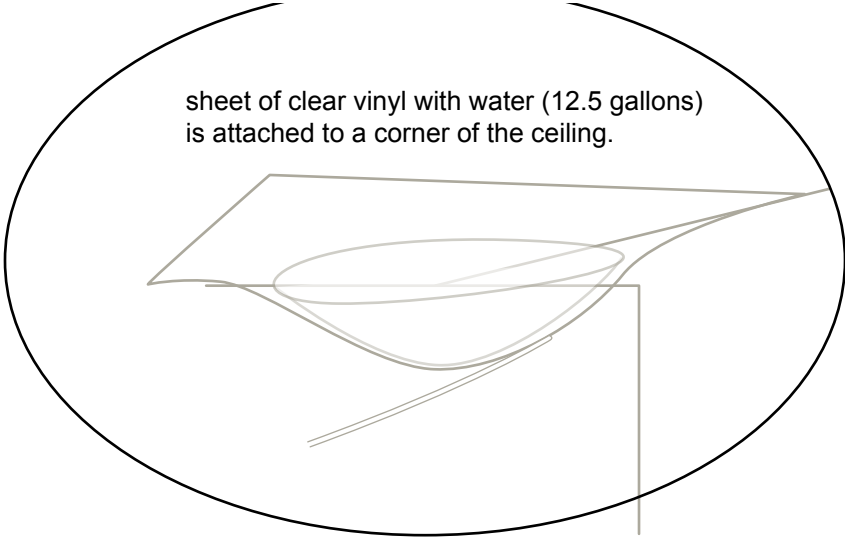

sheetrock

clear vinyl tubing

camera

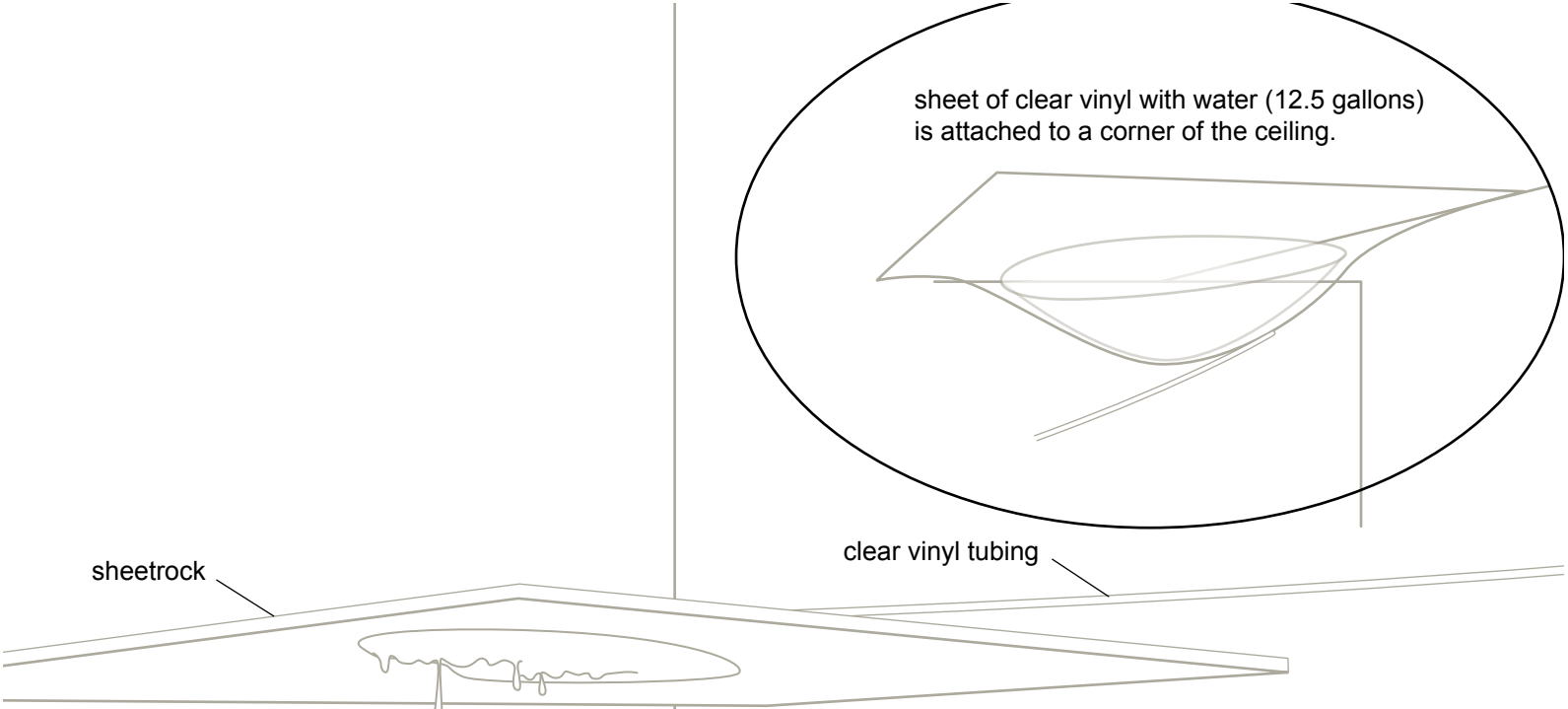

sheetrock

plexi reservoir

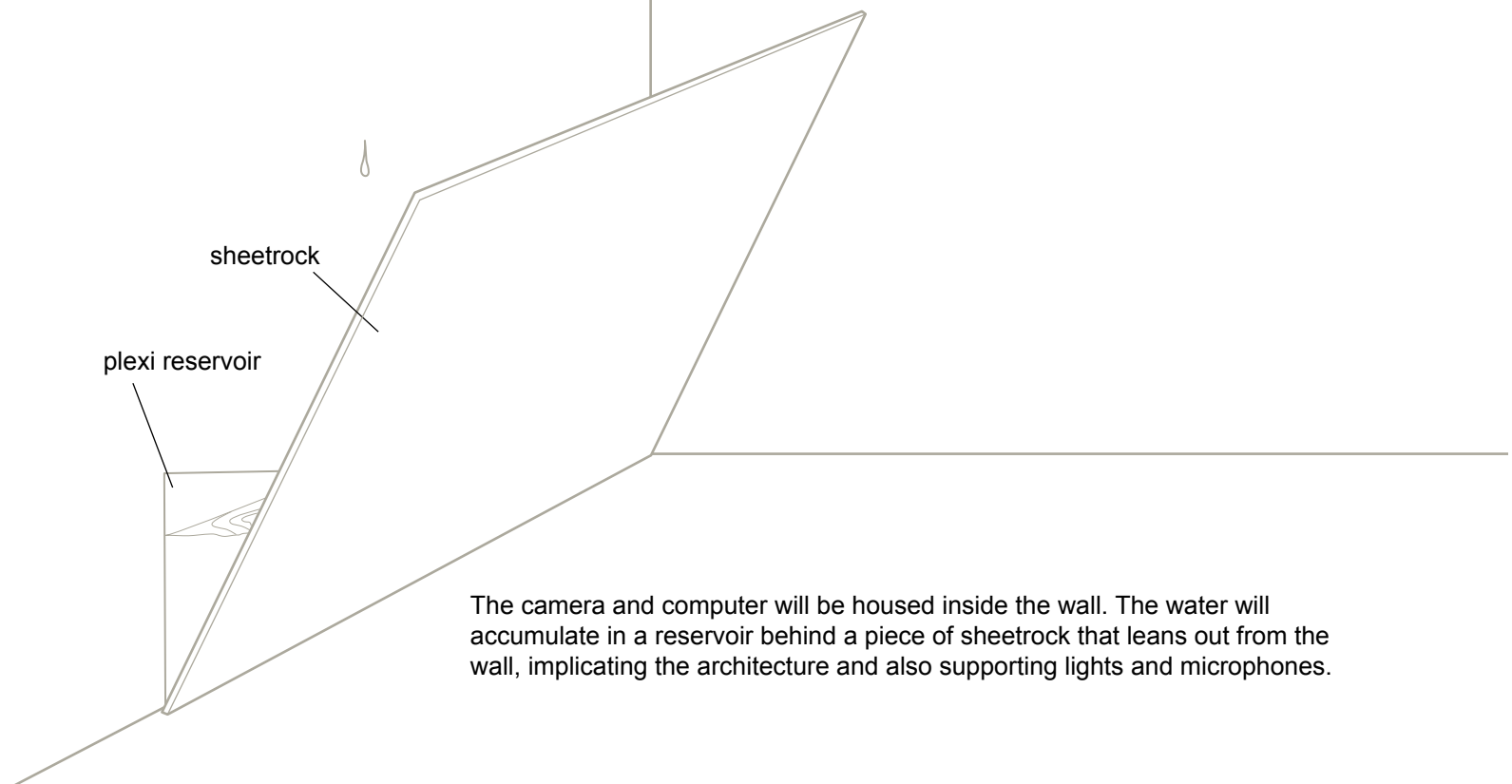

The camera and computer will be housed inside the wall. The water will accumulate in a reservoir behind a piece of sheetrock that leans out from the wall, implicating the architecture and also supporting lights and microphones.